

CW25-TIM GPS Receiver

Description

The CW25-TIM is a small OEM surface mount GPS module that has been specifically designed for use in synchronization and timing applications.

The CW25-TIM has an on-board programmable NCO oscillator that outputs a synthesized frequency up to 30 MHz that is steered by the GPS receiver.

The CW25-TIM has a self survey mode of operation that allows the receiver to enter a position hold mode to allow accurate timing to be continued with only one satellite being tracked.

The output frequency is highly accurate and can achieve full PRC MTIE performance; and can also track satellites and provide GPS synchronization in weak signal areas such as indoor applications. This reduces the need for high antenna placement typically in many environments.

The CW25-TIM is an exceptionally small surface mount package (25mm x 27mm x 4mm) with a highly integrated architecture that requires the minimum of external components allowing easy integration into host systems.

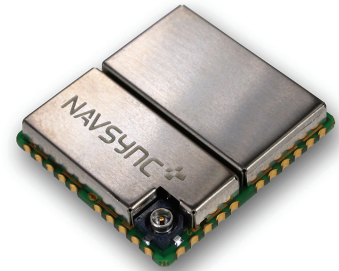

Applications

- Synchronization
- Timing
- Indoor Timing
- GPS timing modules (contact NavSync for further details)

A CW25 Demo board is available for evaluation of the CW25 receiver. A full kit contains the Demo Board with mounted CW25-TIM or CW25-NAV, RS232 serial cable, power supply adaptor (region specific) with a 2.1 mm DC plug and a 3m TNC magnetic patch antenna.

To reduce costs, the CW25 Demo Board can be purchased separately with a pick-and-choose option for above accessories.

See CW25 Demo User Manual for more detailed information on this unit.

Please contact NavSync for pricing information on the full kit or individual items.

Block Diagram

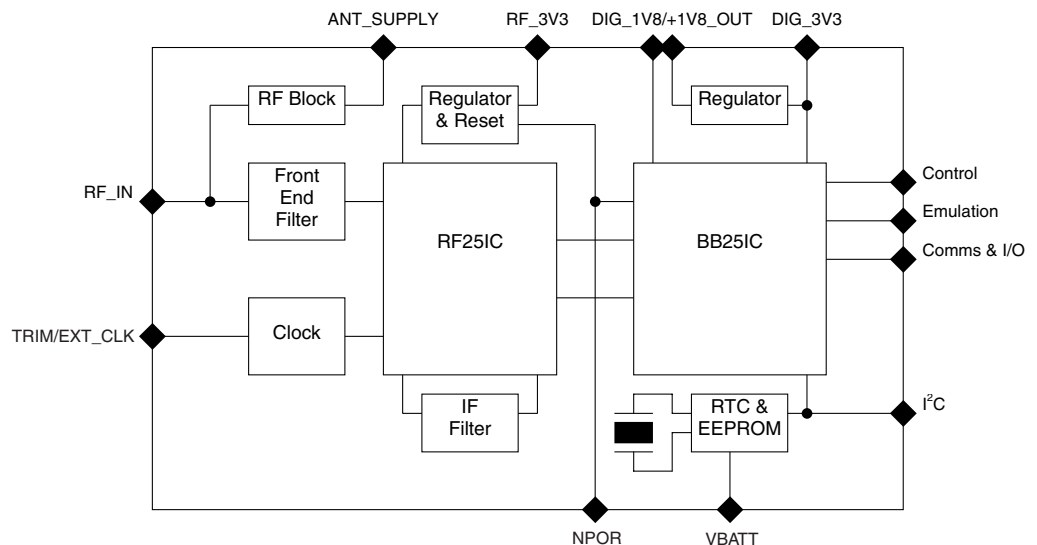

Bulletin	NS18-PB
Revision	09
Date	13 April 2010

CW25-TIM GPS RECEIVER SPECIFICATIONS ¹

SPECIFICATIONS ¹

Physical	Module Dimensions	25mm (D) x 27mm (W) x 4.2mm (H)
	Supply Voltages	3V3 (Digital I/O), 3V3 (RF), 1V8 (Core option), 3V (Standby Battery)
	Operating Temp	-30°C to +80°C
	Storage Temp	-40°C to +85°C ²
	Humidity	5% to 95% non-condensing
	Max Acceleration / Jerk	4g / 1gs ⁻¹ (sustained for less than 5 seconds)
Sensitivity	Acquisition w/Network Assist	-155dBm
	Tracking	-156dBm
	Aquisition Stand Alone	-143dBm
Acquisition Time	Hot Start with Network Assist	Outdoor: <2s Indoor (-148dBm): <5s
	Stand Alone (Outdoor)	Cold: <45s Warm: <38s Hot: <5s Re-acquisition: <0.5s (90% confidence)
Accuracy	Position: Outdoor / Indoor	<5m rms / <50m rms
	Velocity	<0.05ms ⁻¹
	Latency	<200ms
	Raw Measurement Accuracy	Pseudorange <0.3m rms, Carrier phase <5mm rms
	Tracking	Code and carrier coherent
Power	1 Fix Per Second	0.6W typically
	Coma Mode Current (RF3V3+DIG 3V3)	10mA
	Standby Current (VBATT)	1.5µA
Interfaces	Serial	3 UART ports, CMOS levels
	Multi-function I/O	1PPS and Frequency Output available on GPIO [0] Event Counter/Timer Input Up to 4 x GPIO (multi-function) 2 x LED Status Drive I ² C, External Clock (on special build)
	Protocols	Network Assist, NMEA 0183, Proprietary ASCII and binary message formats
	1pps Timing Output	10nS rms accuracy, <5nS resolution User selectable pulse width
	Event Input	30ns rms accuracy, <10ns resolution
	Frequency Output (GPIO [0])	10 Hz to 30 MHz (CW25-TIM)
	Receiver Type	12 parallel channel x 32 taps up to 32 point FFT. Channels, taps and FFT can be switched off to minimize power or simulate simpler designs.
General	Processor	ARM 966E-S on a 0.18µ process at up to 120 MHz.

Note: 1. The features listed above may require specific software builds and may not all be available in the initial release.

2. Please contact factory for other temperature options.